

Mandrino allargatubi a 5 rulli per tubi e curve in acciaio inox a tabelle DIN 11851 e 11852

Tube expander with 5 rolls for stainless steel tubes and bends according to DIN 11851 and 11852 tables

Dudgeon évaseur à 5 galets pour tubes et coudes en acier inox suivant DIN 11851 et 11852

Selbsttätige Rohrwalze mit 5 Rollen für Rohre und Bögen aus rostfreiem Stahl nach Tabellen DIN 11851 und 11852

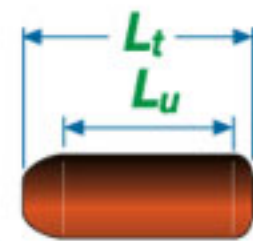

| Rulli Rolls Galets Rollen | L_t | | L_u | |
|------------------------------------|--------|------|--------|------|
| | inches | mm | inches | mm |
| R-DIN 25 | 0.866 | 22,0 | 0.630 | 16,0 |
| R-DIN 32 | 0,984 | 25,0 | 0.709 | 18,0 |
| R-DIN 40 | 1.102 | 28,0 | 0.787 | 20,0 |
| R-DIN 50 | 1.220 | 31,0 | 0.945 | 24,0 |
| R-DIN 60 | 1.338 | 34,0 | 1.024 | 26,0 |
| R-DIN 65 | 1.417 | 36,0 | 1.024 | 26,0 |
| R-DIN 80 | 1.535 | 39,0 | 1.181 | 30,0 |
| R-DIN 90 | 1.535 | 39,0 | 1.181 | 30,0 |
| R-DIN 100 | 1.811 | 46,0 | 1.417 | 36,0 |

Tubo
Tube
Tube
Rohr

Espansione
Expansion
Expansion
Walzbereich

Mandrino
Tube expander
Dudgeon
Rohrwalzen

Rulli
Rolls
Galets
Rollen

Spina
Mandrel
Broche
Dorn

Mandrinatrici consigliate
Suggested rolling machines
Dudgeonneuses conseillées
Empfohlene Rohreinwalzanlagen

Elettriche
Electrical
Electriques
elektrisch

Pneumatiche
Pneumatic
Pneumatiques
pneumatisch

| d_e mm inches | sp inches | mm | d_i inches | mm | inches | mm | Cod. | Cod. | Cod. | inches mm | | |
|-----------------------|----------------|------|-----------------|-------|-------------|------------|---------|----------|-------------------|------------------|----------------------------|--------------|
| 28,0 (1.102") | 0.039 | 1,00 | 1.024 | 26,0 | 0.945÷1.102 | 24,0÷28,0 | DIN/25 | R-DIN25 | S-DIN25 | 0.315" (8,0) | F90 M4/V MS/40 MS/60 | Macrol 450 |
| 34,0 (1.338") | 0.039 | 1,00 | 1.260 | 32,0 | 1.181÷1.338 | 30,0÷34,0 | DIN/32 | R-DIN32 | S-DIN32 | 0.354" (9,0) | F90 M4/L M4/V | Macrol 450 |
| 40,0 (1.575") | 0.039 | 1,00 | 1.496 | 38,0 | 1.417÷1.575 | 36,0÷40,0 | DIN/40 | R-DIN40 | S-DIN40-BS 1.1/2" | 0.472" (12,0) | F90 M4/L M4/V | Macrol 450 |
| 52,0 (2.047") | 0.039 | 1,00 | 1.968 | 50,0 | 1.890÷2.047 | 48,0÷52,0 | DIN/50 | R-DIN50 | S-DIN50-BS 2" | 0.551" (14,0) | F90 M4/L MG/49 | Macrol 200 |
| 60,0 (2.362") | 0.059 | 1,50 | 2.244 | 57,0 | 2.165÷2.362 | 55,0÷60,0 | DIN/60 | R-DIN60 | S-DIN60 | 0.630" (16,0) | F90 M4/L MG/49 | Masterol 180 |
| 70,0 (2.756") | 0.079 | 2,00 | 2.598 | 66,0 | 2.520÷2.716 | 64,0÷69,0 | DIN/65 | R-DIN65 | S-DIN65-BS 2.1/2" | 0.630" (16,0) | F90 MG/49 | Masterol 180 |
| 85,0 (3.346") | 0.079 | 2,00 | 3.189 | 81,0 | 3.110÷3.307 | 79,0÷84,0 | DIN/80 | R-DIN80 | S-DIN80-BS 3" | 0.787" (20,0) | F90 MG/49 | Masterol 90 |
| 93,0 (3.661") | 0.079 | 2,00 | 3.504 | 89,0 | 3.425÷3.622 | 87,0÷92,0 | DIN/90 | R-DIN90 | S-DIN90-BS 3.1/2" | 0.866" (22,0) | F90 MG/49 | Masterol 90 |
| 104,0 (4.094") | 0.079 | 2,00 | 3.937 | 100,0 | 3.858÷4.055 | 98,0÷103,0 | DIN/100 | R-DIN100 | S-DIN100-BS 4" | 0.866" (22,0) | F90 MG/36 | Masterol 90 |

MTT-DIN

Morsetto per taglio tubi da DIN 25 a DIN 100

Clamping lug for cutting tubes from DIN 25 to DIN 100
Mâchoire pour coupe tubes de DIN 25 à DIN 100
Klemme für Schnitt der Rohre von DIN 25 bis DIN 100

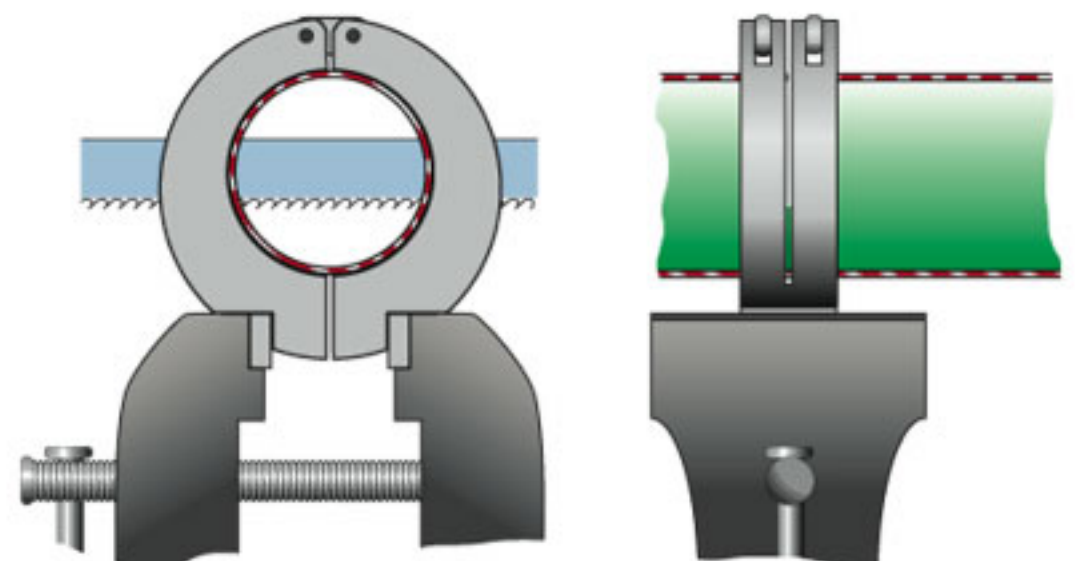

Fig. TE80-F1

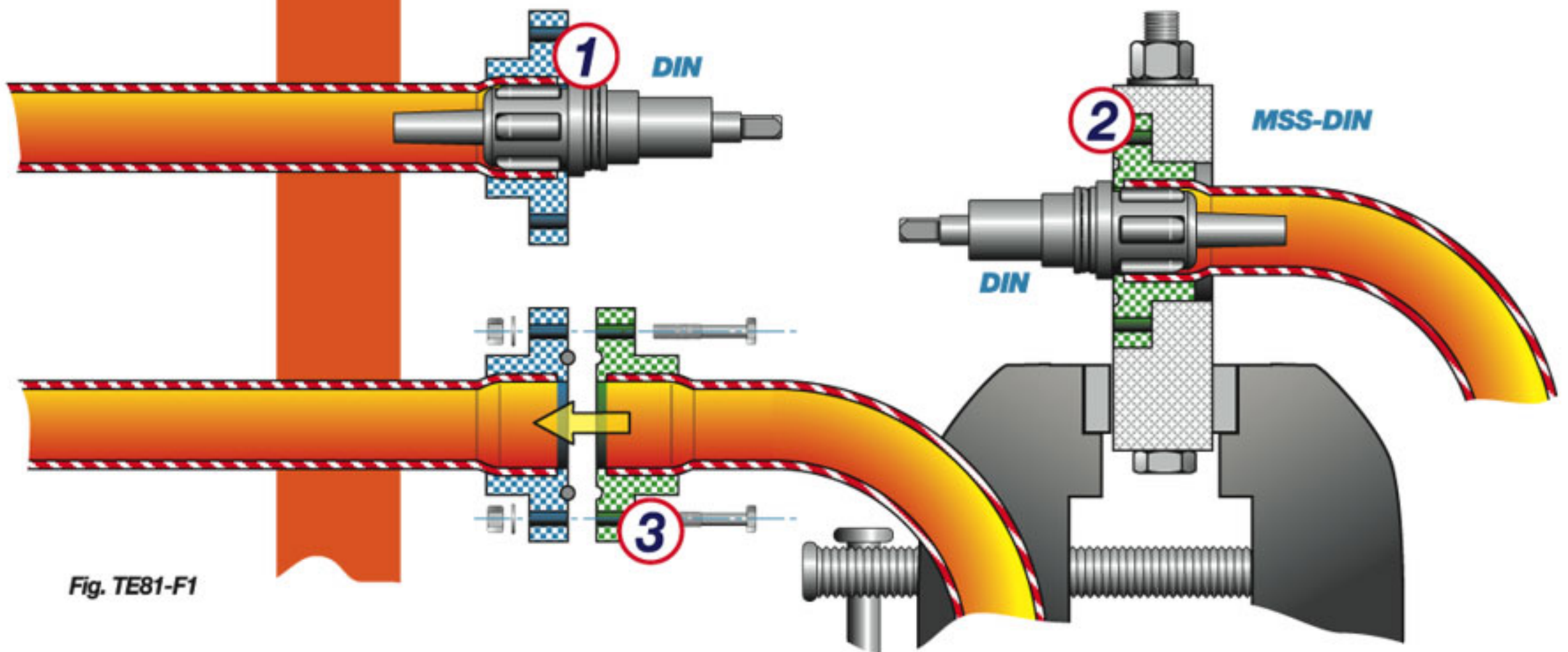

Fig. TE81-F1

MSS-DIN

Morsetto per serraggio singolo per mandrinare tubi da DIN 25 a DIN 100.

Single clamping lug for rolling tubes from DIN 25 to DIN 100.

Mâchoire pour serrage individuel pour dudgeonner tubes de DIN 25 à DIN 100.

Einfach-Klemme zum Einwalzen von Rohren von DIN 25 bis DIN 100.



| <i>de</i> mm inches | MTT-DIN Cod. | MSS-DIN Cod. | MSM-DIN Cod. |
|---------------------------|------------------------|------------------------|---|
| 28,0 (1.102") | MTT-DIN/25 | MSS-DIN/25 |  MSM-DIN |
| 34,0 (1.338") | MTT-DIN/32 | MSS-DIN/32 | |
| 40,0 (1.575") | MTT-DIN/40 | MSS-DIN/40 | |
| 52,0 (2.047") | MTT-DIN/50 | MSS-DIN/50 | |
| 60,0 (2.362") | MTT-DIN/60 | MSS-DIN/60 | |
| 70,0 (2.756") | MTT-DIN/65 | MSS-DIN/65 | |
| 85,0 (3.346") | MTT-DIN/80 | MSS-DIN/80 | |
| 93,0 (3.661") | MTT-DIN/90 | MSS-DIN/90 | |
| 104,0 (4.094") | MTT-DIN/100 | MSS-DIN/100 | |

R a richiesta
on request
sur demande
Auf Anfrage

MSM-DIN

Morsetto per serraggio multiplo per mandrinare tubi da DIN 25 a DIN 50 con bussole intercambiabili.

Multiple clamping lug for rolling tubes from DIN 25 to DIN 50 with interchangeable bushings.

Mâchoire pour serrage multiple pour dudgeonner tubes de DIN 25 à DIN 50 avec douilles interchangeables.

Vielfach-Klemme zum Einwalzen von Rohren von DIN 25 bis DIN 50 mit auswechselbaren Hülse.

